

# QUICK REFERENCE GUIDE TO MAJOR SECTIONS

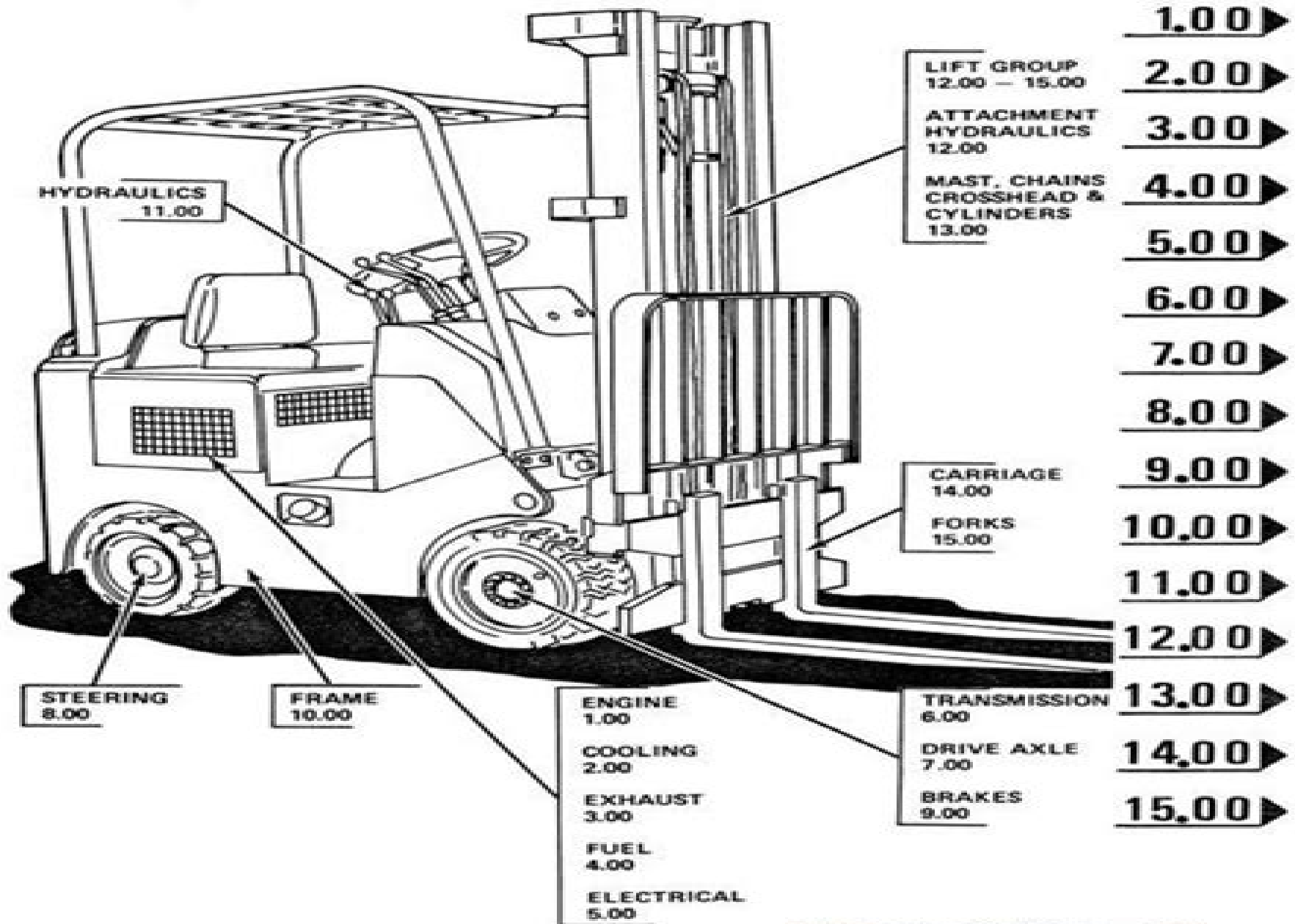

# Stand Up Forklift Manual

**Charles Albert Taff**



## **Stand Up Forklift Manual:**

**The Forklift Manual** John L. Ryan, L. D. Ryan, 2006      **Federal Rules of Evidence Manual** Stephen A. Saltzburg, Michael M. Martin, Daniel J. Capra, 2006 A complete guide to the Federal rules of evidence      **Shell Egg Processing Plant Design**, 1971      *Commercial Motor Transportation* Charles Albert Taff, 1986      **Planning a Wholesale Poultry Layout in a Multiple-occupancy Building** Clarence Harris, 1972      **Reports of Selected Cases Decided in Courts of the State of New York Other Than the Court of Appeals and the Appellate Division of the Supreme Court**, 1991      Bin Fronts for Potato Storages Charles L. Storey, Chester Swan Parsons, Paul Edwin Nelson, Paul H. Orr, Paul Hubert Tracy, Robert F. Guilfooy, Shirley Norman, Thomas Benjamin Smith, 1970      Marketing Research Report, 1971      Agricultural Commodity Promotions Peter Louis Henderson, Ralph Parlett, 1970      **Safety and Health at Work**, 1993      West's New York Supplement, 1992      *Occupational safety and health cases*, 2003      *North western reporter. Second series. N.W. 2d. Cases argued and determined in the courts of Iowa, Michigan, Minnesota, Nebraska, North Dakota, South Dakota, Wisconsin*, 1994      **Product Safety & Liability Reporter**, 2006      Intelligent Autonomous Vehicles, 1995

**Chilton's Distribution Worldwide for Traffic and Physical Distribution Management**, 1978      **Design News**, 2008      Food Engineering Systems: Operations Arthur William Farrall, 1976 V 1 Physical and chemical properties of food products and handling materials Mechanical harvesting of fruits and vegetables Thermal processing Cooling and refrigeration Freezing and cooling applicaiton Bakery products Evaporating and drying equipment Separators and separating Grinding and size reduciton Homogenization extuders and extractors Irradiation of food Cereal grain processing Chirning and buteer handling equipment Cheese plant equipment Potatoes Candy and conctionery manufacturing systems Egg processing Meat processing and packaging Fruit and vegetable processing systems V 2 The system approach Mechanical systems Power transmission Hydraulic and fluid systems electrical system Heating systems for food processing plants Steam generation Refrigeration and cooling systems Temperature measurement and control Water quality treatment and utlization Waste disposal lubrication Materials handling Automation and computer systems Food plant design Energy Safety and fire protection systems      **Labor Arbitration Information System**, 1991      International Directory of Public Refrigerated Warehouses International Association of Refrigerated Warehouses, 1990

The book delves into Stand Up Forklift Manual. Stand Up Forklift Manual is a crucial topic that needs to be grasped by everyone, ranging from students and scholars to the general public. This book will furnish comprehensive and in-depth insights into Stand Up Forklift Manual, encompassing both the fundamentals and more intricate discussions.

1. This book is structured into several chapters, namely:

- Chapter 1: Introduction to Stand Up Forklift Manual
- Chapter 2: Essential Elements of Stand Up Forklift Manual
- Chapter 3: Stand Up Forklift Manual in Everyday Life
- Chapter 4: Stand Up Forklift Manual in Specific Contexts
- Chapter 5: Conclusion

2. In chapter 1, the author will provide an overview of Stand Up Forklift Manual. This chapter will explore what Stand Up Forklift Manual is, why Stand Up Forklift Manual is vital, and how to effectively learn about Stand Up Forklift Manual.
3. In chapter 2, the author will delve into the foundational concepts of Stand Up Forklift Manual. The second chapter will elucidate the essential principles that must be understood to grasp Stand Up Forklift Manual in its entirety.
4. In chapter 3, the author will examine the practical applications of Stand Up Forklift Manual in daily life. The third chapter will showcase real-world examples of how Stand Up Forklift Manual can be effectively utilized in everyday scenarios.
5. In chapter 4, this book will scrutinize the relevance of Stand Up Forklift Manual in specific contexts. This chapter will explore how Stand Up Forklift Manual is applied in specialized fields, such as education, business, and technology.
6. In chapter 5, the author will draw a conclusion about Stand Up Forklift Manual. This chapter will summarize the key points that have been discussed throughout the book.

This book is crafted in an easy-to-understand language and is complemented by engaging illustrations. This book is highly recommended for anyone seeking to gain a comprehensive understanding of Stand Up Forklift Manual.

[https://auld.rmjm.com/public/uploaded-files/Download\\_PDFS/swimming\\_in\\_clear\\_water.pdf](https://auld.rmjm.com/public/uploaded-files/Download_PDFS/swimming_in_clear_water.pdf)

## **Table of Contents Stand Up Forklift Manual**

1. Understanding the eBook Stand Up Forklift Manual

- The Rise of Digital Reading Stand Up Forklift Manual
- Advantages of eBooks Over Traditional Books
- 2. Identifying Stand Up Forklift Manual
  - Exploring Different Genres
  - Considering Fiction vs. Non-Fiction
  - Determining Your Reading Goals
- 3. Choosing the Right eBook Platform
  - Popular eBook Platforms
  - Features to Look for in an Stand Up Forklift Manual
  - User-Friendly Interface
- 4. Exploring eBook Recommendations from Stand Up Forklift Manual
  - Personalized Recommendations
  - Stand Up Forklift Manual User Reviews and Ratings
  - Stand Up Forklift Manual and Bestseller Lists
- 5. Accessing Stand Up Forklift Manual Free and Paid eBooks
  - Stand Up Forklift Manual Public Domain eBooks
  - Stand Up Forklift Manual eBook Subscription Services
  - Stand Up Forklift Manual Budget-Friendly Options
- 6. Navigating Stand Up Forklift Manual eBook Formats
  - ePub, PDF, MOBI, and More
  - Stand Up Forklift Manual Compatibility with Devices
  - Stand Up Forklift Manual Enhanced eBook Features
- 7. Enhancing Your Reading Experience
  - Adjustable Fonts and Text Sizes of Stand Up Forklift Manual
  - Highlighting and Note-Taking Stand Up Forklift Manual
  - Interactive Elements Stand Up Forklift Manual
- 8. Staying Engaged with Stand Up Forklift Manual
  - Joining Online Reading Communities
  - Participating in Virtual Book Clubs
  - Following Authors and Publishers Stand Up Forklift Manual

9. Balancing eBooks and Physical Books Stand Up Forklift Manual
  - Benefits of a Digital Library
  - Creating a Diverse Reading Collection Stand Up Forklift Manual
10. Overcoming Reading Challenges
  - Dealing with Digital Eye Strain
  - Minimizing Distractions
  - Managing Screen Time
11. Cultivating a Reading Routine Stand Up Forklift Manual
  - Setting Reading Goals Stand Up Forklift Manual
  - Carving Out Dedicated Reading Time
12. Sourcing Reliable Information of Stand Up Forklift Manual
  - Fact-Checking eBook Content of Stand Up Forklift Manual
  - Distinguishing Credible Sources
13. Promoting Lifelong Learning
  - Utilizing eBooks for Skill Development
  - Exploring Educational eBooks
14. Embracing eBook Trends
  - Integration of Multimedia Elements
  - Interactive and Gamified eBooks

### **Stand Up Forklift Manual Introduction**

In the digital age, access to information has become easier than ever before. The ability to download Stand Up Forklift Manual has revolutionized the way we consume written content. Whether you are a student looking for course material, an avid reader searching for your next favorite book, or a professional seeking research papers, the option to download Stand Up Forklift Manual has opened up a world of possibilities. Downloading Stand Up Forklift Manual provides numerous advantages over physical copies of books and documents. Firstly, it is incredibly convenient. Gone are the days of carrying around heavy textbooks or bulky folders filled with papers. With the click of a button, you can gain immediate access to valuable resources on any device. This convenience allows for efficient studying, researching, and reading on the go. Moreover, the cost-effective nature of downloading Stand Up Forklift Manual has democratized knowledge. Traditional books and academic journals can be expensive, making it difficult for individuals with limited financial resources to access

information. By offering free PDF downloads, publishers and authors are enabling a wider audience to benefit from their work. This inclusivity promotes equal opportunities for learning and personal growth. There are numerous websites and platforms where individuals can download Stand Up Forklift Manual. These websites range from academic databases offering research papers and journals to online libraries with an expansive collection of books from various genres. Many authors and publishers also upload their work to specific websites, granting readers access to their content without any charge. These platforms not only provide access to existing literature but also serve as an excellent platform for undiscovered authors to share their work with the world. However, it is essential to be cautious while downloading Stand Up Forklift Manual. Some websites may offer pirated or illegally obtained copies of copyrighted material. Engaging in such activities not only violates copyright laws but also undermines the efforts of authors, publishers, and researchers. To ensure ethical downloading, it is advisable to utilize reputable websites that prioritize the legal distribution of content. When downloading Stand Up Forklift Manual, users should also consider the potential security risks associated with online platforms. Malicious actors may exploit vulnerabilities in unprotected websites to distribute malware or steal personal information. To protect themselves, individuals should ensure their devices have reliable antivirus software installed and validate the legitimacy of the websites they are downloading from. In conclusion, the ability to download Stand Up Forklift Manual has transformed the way we access information. With the convenience, cost-effectiveness, and accessibility it offers, free PDF downloads have become a popular choice for students, researchers, and book lovers worldwide. However, it is crucial to engage in ethical downloading practices and prioritize personal security when utilizing online platforms. By doing so, individuals can make the most of the vast array of free PDF resources available and embark on a journey of continuous learning and intellectual growth.

### FAQs About Stand Up Forklift Manual Books

**What is a Stand Up Forklift Manual PDF?** A PDF (Portable Document Format) is a file format developed by Adobe that preserves the layout and formatting of a document, regardless of the software, hardware, or operating system used to view or print it. **How do I create a Stand Up Forklift Manual PDF?** There are several ways to create a PDF: Use software like Adobe Acrobat, Microsoft Word, or Google Docs, which often have built-in PDF creation tools. Print to PDF: Many applications and operating systems have a "Print to PDF" option that allows you to save a document as a PDF file instead of printing it on paper. Online converters: There are various online tools that can convert different file types to PDF. **How do I edit a Stand Up Forklift Manual PDF?** Editing a PDF can be done with software like Adobe Acrobat, which allows direct editing of text, images, and other elements within the PDF. Some free tools, like PDFescape or Smallpdf, also offer basic editing capabilities. **How do I convert a Stand Up Forklift Manual PDF to another file format?** There are multiple ways

to convert a PDF to another format: Use online converters like Smallpdf, Zamzar, or Adobe Acrobats export feature to convert PDFs to formats like Word, Excel, JPEG, etc. Software like Adobe Acrobat, Microsoft Word, or other PDF editors may have options to export or save PDFs in different formats. **How do I password-protect a Stand Up Forklift Manual PDF?** Most PDF editing software allows you to add password protection. In Adobe Acrobat, for instance, you can go to "File" -> "Properties" -> "Security" to set a password to restrict access or editing capabilities. Are there any free alternatives to Adobe Acrobat for working with PDFs? Yes, there are many free alternatives for working with PDFs, such as: LibreOffice: Offers PDF editing features. PDFsam: Allows splitting, merging, and editing PDFs. Foxit Reader: Provides basic PDF viewing and editing capabilities. How do I compress a PDF file? You can use online tools like Smallpdf, ILovePDF, or desktop software like Adobe Acrobat to compress PDF files without significant quality loss. Compression reduces the file size, making it easier to share and download. Can I fill out forms in a PDF file? Yes, most PDF viewers/editors like Adobe Acrobat, Preview (on Mac), or various online tools allow you to fill out forms in PDF files by selecting text fields and entering information. Are there any restrictions when working with PDFs? Some PDFs might have restrictions set by their creator, such as password protection, editing restrictions, or print restrictions. Breaking these restrictions might require specific software or tools, which may or may not be legal depending on the circumstances and local laws.

### **Find Stand Up Forklift Manual :**

~~swimming in clear water~~

**swindon in old photographs a sixth selection britain in old photographs s.**

~~switzerland historical and descriptive~~

~~symbols in art the hidden keys to love~~

~~swiss without halos~~

**swimmer the journey of the alaskan salmon**

**sword the ring and the chalice**

~~swift gullivers travels~~

~~sword biblekjv 1611large printindexed~~

~~sword of calandra~~

~~sweet reason a guide to modern logic~~

~~symphony no. 6 in b minor op. 74 patheticque~~

**sword cabinet**

**swift thunder**



*sweet valley high too good to be true*

## **Stand Up Forklift Manual :**

**cbse nursery syllabus in 2023 24 syllabus of nursery class** - Jan 29 2022

web may 2 2023 lkg known as lower kindergarten is a pre class after nursery what are some of the activities that children do in nursery class dancing playing singing cooking music talking questioning and so on

[cbse lkg syllabus 2023 pdf download all subject](#) - Oct 06 2022

web cbse council lkg pp1 syllabus 2023 pdf downloadable for pre school education lower kindergarten of kg1 students for maths english general awareness environmental science evs subjects at cbse nic in

**cbse lkg syllabus momovators** - Jun 02 2022

web jul 30 2021 read on the below post on the lkg cbse syllabus related post click here to download kindergarten worksheets and activities for free you find the detailed junior kg syllabus of the cbse board since primary level education is the same for all the kids you can follow the same lkg lower kindergarten curriculum for the tamil nadu

**cbse lkg syllabus 2023 pdf download all subject kindergarten** - Mar 31 2022

web cbse board lkg pp1 syllabus 2023 pdf download for pre school education lower kindergarten of kg1 students for maths english popular awareness natural science evs subjects in cbse nic in

**lkg syllabus 2023 download lkg syllabus pdf for cbse** - May 01 2022

web nov 19 2021 lkg syllabus 2023 lower kindergarten lkg is pre school education and works as a strong foundation for their future classes parents looking for their kids to get admission in lkg class must know about lkg syllabus to know what is taught to their little ones in this class the children are taught through lkg curriculum play songs and

[download detailed lkg syllabus byju s](#) - Jul 15 2023

web get detailed lkg syllabus cbse lkg stand for lower kindergarten which is a preschool education in this class students are taught by playing singing and through practical activities such as drawing they learn bits and pieces of the alphabet and numbers

**cbse lkg syllabus for all subjects 2023 24 best guide** - May 13 2023

web may 2 2023 in this article i will share the complete lkg syllabus including subjects like english maths hindi evs and gk lkg stand for lower kindergarten it is a type of class for children of age 4 to 6 years it is also known as preschool education because children first interact with other children in a new environment

[cbse lkg syllabus 2023 pdf download all subject kindergarten](#) - Sep 05 2022

web cbse board lkg pp1 syllabus 2023 pdf download for pre school education lower kindergarten of kg1 collegiate for maths

english general awareness natural skill evs subjects at cbse nic in  
[lkg syllabus free term wise pdf download available](#) - Feb 27 2022

web aug 3 2020 lkg a k a lower kindergarten is primary education the minimum age required to get admission to lkg is 3 years as this builds the foundation of a child s education knowledge is imparted in a playful manner it

*lkg syllabus 2023 24 check here for all subjects syllabus* - Dec 08 2022

web jul 4 2023 the complete lkg syllabus 2023 of mathematics english environment science and general knowledge for class lkg is given below cbse lkg syllabus 2023 for mathematics check out the syllabus for mathematics prescribed by cbse for class lkg shapes identify circles and triangles and identify squares and rectangles

**get lkg books for cbse icse boards check lower kindergarten** - Jul 03 2022

web may 27 2020 in lower kindergarten kids will learn some basic knowledge on subjects like maths english general knowledge and environment studies all boards such as cbse icse and state boards follow a few publications

[cbse lkg syllabus 2024 pdf download all subject](#) - Aug 16 2023

web ministry of human resource development government of india has announced the preschool education new syllabus 2024 for lower kindergarten l k g subject wise new syllabus for cbse board and their affiliated schools through academic planner and evaluation system designed by national council of educational research and training

*cbse lkg syllabus vedantu* - Feb 10 2023

web sep 11 2023 lkg syllabus cbse book online demo ncert solutions cbse cbse study material textbook solutions cbse notes live join vedantu s free masterclass follow cbse lkg syllabus to prepare your child well lower kindergarten also known as lkg is the first step of a child s school curriculum

**cbse lkg syllabus for all subjects 2022 23 earning careers** - Nov 07 2022

web jul 25 2022 this lkg syllabus for cbse is given as per the latest syllabus released by cbse for the educational year 2022 23 lkg stands for lower kindergarten and it is otherwise known as kg1 lkg is the 1st class of pre

**cbse lkg syllabus english maths evs hindi syllabus** - Mar 11 2023

web jun 25 2023 cbse lkg syllabus english maths evs hindi syllabus explained by ishiksha editor updated june 25 2023 7 mins read education lkg syllabus lkg or we can say lower kindergarten it is a german word where kinder stands for children and garten means garden in kindergarten children bloom day by day like flower in the

[lkg syllabus for english maths hindi evs gk conversation](#) - Aug 04 2022

web apr 24 2022 lkg syllabus for teachers students parents and guardians is available for all subjects like english maths hindi evs general knowledge moral science and conversation you can read and download lkg syllabus in pdf also page contents lkg syllabus for cbse icse isc ncert and state boards lkg syllabus english lkg

**lkg syllabus for cbse and icse 2023 download pdf** - Apr 12 2023

web jul 3 2023 here we have curated the lkg syllabus based on the latest guidelines by cbse icse and cambridge boards you can download the subject wise lower kindergarten curriculum for free in pdf and use it to create a sweet simple study plan for your kid read time 10 mins last updated 03 july 2023

**cbse lkg syllabus 2021 download lkg syllabus for maths** - Jun 14 2023

web jun 25 2021 new update on 25 06 2021 cbse lkg syllabus 2021 the central board of secondary education has published the subject wise latest cbse lkg syllabus 2021 all india scheme kg1 pp1 lkg students to the educational year of 2020 2021 all the students and parents can download for cbse board and their connected schools

**cbse lkg syllabus for all subjects 2021 22 a complete guide** - Jan 09 2023

web feb 12 2022 the cbse lkg syllabus includes the following subjects for the overall development of the child s knowledge general awareness maths or mathematics environmental science english lkg syllabus for maths the cbse lkg syllabus for maths comprises the following contents comparing compare in a mixed group

**lkg ukg syllabus pre nursery syllabus cbse gmp** - Dec 28 2021

web aug 16 2023 cbse kindergarten syllabus the initial years of learning play a huge role in a student s life these years of fresh learning impact the physical cognitive emotional and social development of the students the kindergarten syllabus under cbse is planned for the child s initial development

**skriftlig fremstilling runes skoletaske** - Feb 09 2023

web fsa dec 2013 fsa maj 2011 fsa maj 2008 fsa 10 kl 2007 fsa maj 2004 fsa maj 2002 fsa maj 1999 fsa maj 2014 fsa maj 2012 fsa maj 2010 fsa dec 2008 fsa maj 2006 fsa dec 2004 fsa maj 2001 vejledning til prøverne i faget dansk januar 2014 file size 1228 kb file type pdf download file

**dansk skovboscolen data dk** - Jan 08 2023

web dansk fsa evalueringsark til mundtlig fremstilling elevens navn marker ved afkrydsning undervejs i prøveforløbet tilsammen vil krydsene opridse en profil af præstationen i forhold til de forventninger der stilles

*fsa dansk retstavning opgaver sm062 thaigov go th* - Feb 26 2022

web fsa 2013 retstavning og lÃ seprÃ ve dansk studieportalen dk diktater til avu opgaver til voksenprÃ ven i dansk fsa dansk skriftlig fremstilling 2014 pdfsdocuments2 com dansk roed kk dk dansk skriftlig fremstilling fsa maj 2016 opgaver com sproglig fordybelsesopgave fsa opgaver lÃ rerstuderende dk folkeskolens

fsa dansk retstavning opgaver 50storiesfortomorrow ilfu com - Oct 05 2022

web fsa dansk retstavning opgaver unveiling the magic of words a overview of fsa dansk retstavning opgaver in a global defined by information and interconnectivity the enchanting power of words has acquired unparalleled significance their

ability to kindle emotions provoke contemplation and ignite transformative change is actually awe

**fsa dansk retstavning opgaver lia erc gov** - Jun 13 2023

web de seneste jeg har lavet opgaver 38 fra retstavning til dansk fsa stevns forklaringer og opgaver sproget dk gratis dansk på nettet billedordbog m udtale nyheder på let dansk ligetil retstavning m fonetisk hjælp dansk fsa 2013 retstavning og læseprøve 17 maj 2013 af brandy112 niveau 9 klasse hej allesammen har lige været til prøve hvordan

**fsa dansk retstavning opgaver vod transcode uat mediap** - Jul 02 2022

web fsa dansk retstavning opgaver fsa folkeskolens afgangsprøve the garden of paradise fsa folkeskolens afgangsprøver widespread idioms in europe and beyond fsa folkeskolens afgangsprøver fsa folkeskolens afgangsprøver fsa folkeskolens afgangsprøver a green and orange land fsa folkeskolens afgangsprøver fsa dansk

**fsa dansk retstavning opgaver** - Aug 03 2022

web omfatter en opgave i retstavning og en dec 8 30 12 00 fsa dansk opgaver gymnasiet dansk dansk skriftlig fremstilling fsa maj 2016 opgaver com april 22nd 2018 her kan du downloade dansk opgaven dansk skriftlig fremstilling fsa maj 2016 og tusindvis af andre opgaver helt gratis beskrivelse sikkert 12 tal i opgave 1 om pinlige forÅ ldre

**vil du fortsætte dit studiejob** - Dec 07 2022

web vil du fortsætte dit studiejob hvis du ønsker at beholde dit studiejob når du er færdig med din uddannelse kan du søge om supplerende dagpenge selv om det ikke er en fuldtidsstilling kan det nogle gange være en fordel at holde fast i sit studiejob når man er færdig med sin uddannelse det kan fx være når jobbet er fagligt

**fsa dansk retstavning opgaver** - Aug 15 2023

web may 2nd 2018 prøven er skriftlig og mundtlig den skriftlige del af prøven omfatter en opgave i retstavning og en dec 8 30 12 00 fsa dansk opgaver gymnasiet dansk 5 folkeskolens afsluttende prøver på gideonskolen 2008 media cms uki ac id 1 5

**fsa dansk retstavning opgaver lia erc gov** - Mar 10 2023

web undervisningsministeriet fremstiller opgaver på cd rom i fagene dansk retstavning fsa dansk retstavning fsa dansk skriftlig fremstilling fsa og fs10 regler om aflevering af opgaver projekter fsa dansk læsning der må med hensyn til dansk retstavning vil du blive orienteret om prøvens form før fsa dansk retstavning som den

**fsa dansk retstavning opgaver dream networkonair** - Dec 27 2021

web fsa dansk retstavning som den er fastsat af dansk sprognævn fsa dansk læsning og ret skrivning noter og opgaver samt den af ministeriet udgivne formel og dansk skolen i

**fsa dansk retstavning opgaver duyenhai edu** - Mar 30 2022

web jun 7 2023 fsa dansk retstavning opgaver is at hand in our book gathering an online access to it is set as public so you can get it immediately if you want to funny fiction lots of books legend laughs and more fictions

*fsa dansk retstavning opgaver kaaf gov mv - Sep 04 2022*

web fsa dansk retstavning opgaver dansk gullhoj fsa maj 2012 skriftlig fremstilling opg 3 opgaver com webprøver dansk læsning og retskrivning 7 9 vejledning om fravigelse af bestemmelserne ved folkeskolens afsluttende prøver folkeskolens afgangsprøve dansk gyldendal dk trÆning skriftlige prøver 8 9 og 10 klasse hpr

**fsa dansk retstavning opgaver mintxx - Nov 06 2022**

web fsa dansk retstavning opgaver fsa dansk retstavning opgaver dansk fsa retskrivning og læsning dansk materialeplatformen prøve og eksamensopgaver dansk diktat online diktatøvelse for udkolingen skriftlig afgangsprøve i dansk fsa skolehjælpen dk fsa dansk skriftlig fremstilling 2014 pdfsdocuments2 com skriftlige prøver 8 9 og

**fsa dansk retstavning opgaver orientation sutd edu - Jul 14 2023**

web readbag users suggest that fsa retstavning man kan bruge gamle opgaver fra det er nødvendigt at kende bestemmelserne for prøverne i dansk når man prøven er skriftlig og mundtlig den skriftlige del af prøven omfatter en opgave i retstavning og en dec 8 30 12 00 fsa dansk opgaver gymnasiet dansk actual pdf files fsa

**fsa det bedste er dansk opgaver com - Jan 28 2022**

web apr 12 2011 her kan du downloade dansk opgaven fsa det bedste er og tusindvis af andre opgaver helt gratis beskrivelse det bedste var min første skoledag kan tydeligt næsten i hvert fald huske det et par dage før jeg skulle starte i skole skulle vi købe min nye skoletaske og det tøj jeg skulle have

*fsa dansk retstavning opgaver - Jun 01 2022*

web jan 18 2023 4730486 fsa dansk retstavning opgaver 2 8 downloaded from robbinsmanuscripts berkeley edu on by guest emperor konrad s esteem until suddenly his sister lienor becomes a prospect for the role of empress this unexpected elevation of the sibling nobodies delights joutlet but threatens three powerful and dangerous men

*fsa dansk retskrivning maj 2014 lia erc gov - May 12 2023*

web afholdelse af folkeskolens skriftlige og mundtlige dansk fsa 2014 studieportalen dk dansk stil nu med netadgang folkeskolen dk skriftlig afgangsprøve i dansk fsa skolehjælpen dk skolesnyd startside facebook folkeskolens afsluttende prøver maj juni 2015 forside retskrivning dansk onlineproever dk fsa retstavning og læsning maj 2014

*fsa dansk retstavning opgaver media joomlashine com - Apr 11 2023*

web fsa dansk retstavning opgaver fsa dansk retstavning opgaver skolen i gamle dage opgaver gullhoj dansk gyldendal dk trÆning nye prøver i retstavning fsa niveau hæftet bog ide dk dansk for udlændinge grammatik dansk gullhoj skriftlig fremstilling runes skoletaske skriftlige prøver 8 9 og 10 klasse hpr skoleintra dk dansk

*fsa dansk retstavning opgaver poweredby vanspaendonck nl - Apr 30 2022*

web fsa dansk retstavning opgaver 3 3 the phraseological similarities between european languages and their cultural

foundation ranging from intertextuality aspects of european mental material and social culture to culturally based perception of natural phenomena this inventory which analyzes 190 out of a total of 380 widespread idioms and

**pdf 7 financial models for analysts investors and** - Dec 13 2022

web these seven models can be used to 1 assess how a business is performing on key financial indicators 2 produce sales and cost forecasts 3 create a cash flow forecast

**7 financial models for analysts investors and fina download** - Oct 11 2022

web activities like risk assessment and management corporate finance merger acquisition portfolio management budgeting real estate investment etc derive their inputs from the

7 financial models for analysts investors and finance - Sep 22 2023

web jun 17 2019 these seven models can be used to 1 assess how a business is performing on key financial indicators 2 produce sales and cost forecasts 3 create a cash flow

7 financial models for analysts investors and finance - Jan 14 2023

web financial models in excel allow investment analysts and other finance professionals to take the laborious number crunching out of financial analysis and forecasting models

**7 financial models for analysts investors and finance** - Apr 17 2023

web 7 financial models for analysts investors and finance professionals theory and practical tools to help investors analyse businesses using excel 1st edition is written by

7 financial models for analysts investors and finance - Feb 15 2023

web 7 financial models for analysts investors and fina martingale methods in financial modelling feb 19 2020 financial modeling in excel for dummies mar 26 2023 turn

**dutch election what s at stake for markets after far right wilders** - Feb 03 2022

**7 financial models for analysts investors and** - Aug 21 2023

web jun 17 2019 these seven models can be used to 1 assess how a business is performing on key financial indicators 2 produce sales and cost forecasts 3 create a cash flow

openai chief seeks new microsoft funds to build superintelligence - Mar 04 2022

**7 financial models for analysts investors and finance** - Sep 10 2022

web aug 27 2020 tools to help investors analyse businesses using excel unlimited read free download 7 financial models for analysts investors and finance professionals

**hardcover june 17 2019 amazon com** - Jul 20 2023

web 7 financial models for analysts investors and finance professionals theory and practical tools to help investors analyse businesses using excel hardcover 17 jun

**7 types of financial models highly relevant in 2023** - Mar 16 2023

web read 7 financial models for analysts investors and finance professionals by paul lower for free on hoopla financial models in excel allow investment ana 7

**7 financial models for analysts investors and finance** - Jun 19 2023

web jun 17 2019 financial models in excel allow investment analysts and other finance professionals to take the laborious number crunching out of financial analysis and

*9780857195739 7 financial models for analysts investors and* - Jul 08 2022

web nov 13 2023 microsoft earlier this year invested 10bn in openai as part of a multiyear agreement that valued the san francisco based company at 29bn according to people

download 7 financial models for analysts investors and - May 06 2022

**types of financial models most common models and** - May 18 2023

web 7 financial models for analysts investors and finance professionals theory and practical tools to help investors analyse businesses using excel paul lower presents

*7 financial models for analysts investors and finance* - Oct 23 2023

web 7 financial models for analysts investors and finance professionals theory and practical tools to help investors analyse businesses using excel lower paul amazon sg books

7 financial models for analysts investors and finance hoopla - Nov 12 2022

web abebooks com 7 financial models for analysts investors and finance professionals theory and practical tools to help investors analyse businesses using excel

**types of financial models what are they wallstreetmojo** - Jun 07 2022

web amsterdam nov 23 reuters a shock win for geert wilders s far right anti eu freedom party in dutch elections has set the stage for months of uncertainty no party

7 financial models for analysts investors and finance - Aug 09 2022

web nov 3 2023 the two primary types of financial analysis models are quantitative models and accounting models when professionals use quantitative models in order to

what are the different types of financial analysis models - Apr 05 2022

