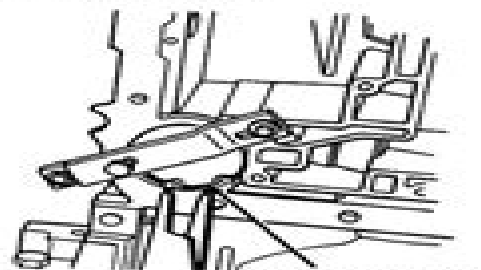

IN-VEHICLE SERVICE (Continued)

1-2 Accumulator Cover

1-2 ACCUMULATOR
PISTON RETAINING
RING 97632

D14008-A

1-2 Accumulator

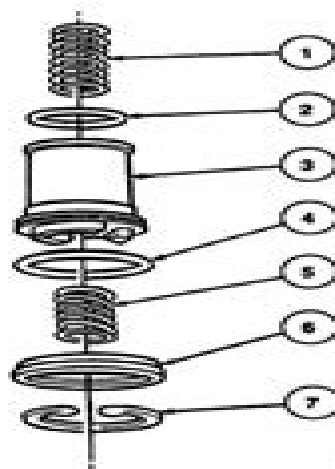

D10175-B

Item	Part Number	Description
1	7F264	1-2 Accumulator Spring
2	7F248	Accumulator Piston Seal
3	7F251	Accumulator Piston
4	7F249	Lower Accumulator Seal

(Continued)

Item	Part Number	Description
5	7F264	1-2 Accumulator Spring
6	7G300	Cover and Seal Assy
7	7384	Accumulator Piston Retaining Ring

9. **NOTE:** Carefully note the location of the 1-2 accumulator spring and assemble in the same positions. Some models may use two 1-2 accumulator springs. The accumulator piston may also vary with applications.

Remove accumulator piston and 1-2 accumulator spring.

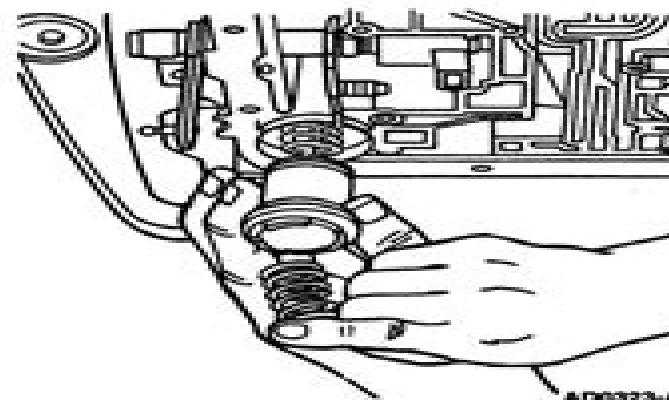

AD0323-A

Installation

1. **NOTE:** This is not an ordinary installation procedure and does not compensate for band wear.

Install reverse band servo spring, reverse band servo piston and rod. When piston and rod assembly replacement becomes necessary, or when the reverse band has been replaced, determine the correct length of the reverse servo piston and rod, proceed as follows:

- Lubricate the reverse piston seal to facilitate assembly and to prevent damage to the seal.
- Install the reverse servo piston and return spring. Do not install the piston cover or retaining ring.

97 Mustang Service Manual

Siddappa N.Byrareddy



97 Mustang Service Manual:

WALNECK'S CLASSIC CYCLE TRADER, NOVEMBER 1997 Causey Enterprises, LLC, *Chilton Ford Service Manual*, 2004 *New Serial Titles*, 1997 A union list of serials commencing publication after Dec 31 1949 **Mustang Restoration Handbook** Don Taylor, 1987-01-01 Ground up or section by section this guide will show you how to restore your 1965 70 Mustang to like new condition Packed with dozens of identification charts and more than 450 photos and drawings the guide covers year by year equipment changes and disassembly and assembly A Mustang suppliers list is a bonus **Chilton's Auto Repair Manual 1989-1993**, 1992-10 Documents specifications repairs and servicing procedures for individual models and provides information on component repair and overhaul [Subject Guide to Books in Print](#), 2001 **Chilton's Auto Repair Manual**, 1964 Each edition includes information for that year and several previous years *Chilton's Auto Service Manual*, 2002 **American Book Publishing Record**, 1999 **Cars & Parts**, 1994 **Lotus Europa - Colin Chapman's Mid-engined Masterpiece** Matthew Vale, 2022 Explores the design development and production of the Lotus Europa Lotus s first mid engined road car It covers the Renault powered Series 1 and 2 cars the Lotus Twin Cam engined versions and the Type 47 racing models *Popular Mechanics*, 1983-05 Popular Mechanics inspires instructs and influences readers to help them master the modern world Whether it s practical DIY home improvement tips gadgets and digital technology information on the newest cars or the latest breakthroughs in science PM is the ultimate guide to our high tech lifestyle **Mechanix Illustrated**, 1983 **Construction Methods**, 1955 *National Union Catalog*, Includes entries for maps and atlases **Whitaker's Cumulative Book List**, 1974 **Library of Congress Catalogs** Library of Congress, 1976 **Road and Track**, 1984 **Forthcoming Books** Rose Army, 2002-04 *Books in Print*, 1977

This Enthralling Realm of E-book Books: A Comprehensive Guide Revealing the Benefits of Kindle Books: A World of Convenience and Versatility E-book books, with their inherent portability and ease of access, have liberated readers from the constraints of physical books. Gone are the days of carrying bulky novels or carefully searching for particular titles in bookstores. Kindle devices, stylish and portable, seamlessly store an extensive library of books, allowing readers to indulge in their favorite reads whenever, anywhere. Whether commuting on a busy train, lounging on a sun-kissed beach, or just cozying up in bed, E-book books provide an unparalleled level of convenience. A Literary World Unfolded: Discovering the Wide Array of E-book 97 Mustang Service Manual 97 Mustang Service Manual The E-book Store, a digital treasure trove of bookish gems, boasts an extensive collection of books spanning varied genres, catering to every readers taste and choice. From gripping fiction and mind-stimulating non-fiction to timeless classics and contemporary bestsellers, the E-book Shop offers an unparalleled variety of titles to explore. Whether looking for escape through immersive tales of fantasy and adventure, delving into the depths of historical narratives, or broadening ones understanding with insightful works of scientific and philosophy, the Kindle Shop provides a gateway to a bookish world brimming with limitless possibilities. A Game-changing Force in the Bookish Scene: The Enduring Influence of E-book Books 97 Mustang Service Manual The advent of E-book books has certainly reshaped the bookish landscape, introducing a model shift in the way books are published, distributed, and consumed. Traditional publication houses have embraced the online revolution, adapting their approaches to accommodate the growing need for e-books. This has led to a rise in the accessibility of E-book titles, ensuring that readers have entry to a vast array of bookish works at their fingers. Moreover, E-book books have democratized entry to books, breaking down geographical barriers and offering readers worldwide with similar opportunities to engage with the written word. Irrespective of their place or socioeconomic background, individuals can now immerse themselves in the captivating world of literature, fostering a global community of readers. Conclusion: Embracing the E-book Experience 97 Mustang Service Manual E-book books 97 Mustang Service Manual, with their inherent ease, versatility, and vast array of titles, have certainly transformed the way we experience literature. They offer readers the freedom to discover the limitless realm of written expression, anytime, anywhere. As we continue to travel the ever-evolving online landscape, Kindle books stand as testament to the persistent power of storytelling, ensuring that the joy of reading remains reachable to all.

<https://auld.rmjm.com/data/browse/HomePages/state%20estimates%20of%20outputs%20employment%20and%20payrolls%201947%201958%201963.pdf>

Table of Contents 97 Mustang Service Manual

1. Understanding the eBook 97 Mustang Service Manual
 - The Rise of Digital Reading 97 Mustang Service Manual
 - Advantages of eBooks Over Traditional Books
2. Identifying 97 Mustang Service Manual
 - Exploring Different Genres
 - Considering Fiction vs. Non-Fiction
 - Determining Your Reading Goals
3. Choosing the Right eBook Platform
 - Popular eBook Platforms
 - Features to Look for in an 97 Mustang Service Manual
 - User-Friendly Interface
4. Exploring eBook Recommendations from 97 Mustang Service Manual
 - Personalized Recommendations
 - 97 Mustang Service Manual User Reviews and Ratings
 - 97 Mustang Service Manual and Bestseller Lists
5. Accessing 97 Mustang Service Manual Free and Paid eBooks
 - 97 Mustang Service Manual Public Domain eBooks
 - 97 Mustang Service Manual eBook Subscription Services
 - 97 Mustang Service Manual Budget-Friendly Options
6. Navigating 97 Mustang Service Manual eBook Formats
 - ePub, PDF, MOBI, and More
 - 97 Mustang Service Manual Compatibility with Devices
 - 97 Mustang Service Manual Enhanced eBook Features
7. Enhancing Your Reading Experience
 - Adjustable Fonts and Text Sizes of 97 Mustang Service Manual
 - Highlighting and Note-Taking 97 Mustang Service Manual
 - Interactive Elements 97 Mustang Service Manual
8. Staying Engaged with 97 Mustang Service Manual

- Joining Online Reading Communities
 - Participating in Virtual Book Clubs
 - Following Authors and Publishers 97 Mustang Service Manual
9. Balancing eBooks and Physical Books 97 Mustang Service Manual
- Benefits of a Digital Library
 - Creating a Diverse Reading Collection 97 Mustang Service Manual
10. Overcoming Reading Challenges
- Dealing with Digital Eye Strain
 - Minimizing Distractions
 - Managing Screen Time
11. Cultivating a Reading Routine 97 Mustang Service Manual
- Setting Reading Goals 97 Mustang Service Manual
 - Carving Out Dedicated Reading Time
12. Sourcing Reliable Information of 97 Mustang Service Manual
- Fact-Checking eBook Content of 97 Mustang Service Manual
 - Distinguishing Credible Sources
13. Promoting Lifelong Learning
- Utilizing eBooks for Skill Development
 - Exploring Educational eBooks
14. Embracing eBook Trends
- Integration of Multimedia Elements
 - Interactive and Gamified eBooks

97 Mustang Service Manual Introduction

In the digital age, access to information has become easier than ever before. The ability to download 97 Mustang Service Manual has revolutionized the way we consume written content. Whether you are a student looking for course material, an avid reader searching for your next favorite book, or a professional seeking research papers, the option to download 97 Mustang Service Manual has opened up a world of possibilities. Downloading 97 Mustang Service Manual provides numerous advantages over physical copies of books and documents. Firstly, it is incredibly convenient. Gone are the days of carrying around heavy textbooks or bulky folders filled with papers. With the click of a button, you can gain immediate access to

valuable resources on any device. This convenience allows for efficient studying, researching, and reading on the go. Moreover, the cost-effective nature of downloading 97 Mustang Service Manual has democratized knowledge. Traditional books and academic journals can be expensive, making it difficult for individuals with limited financial resources to access information. By offering free PDF downloads, publishers and authors are enabling a wider audience to benefit from their work. This inclusivity promotes equal opportunities for learning and personal growth. There are numerous websites and platforms where individuals can download 97 Mustang Service Manual. These websites range from academic databases offering research papers and journals to online libraries with an expansive collection of books from various genres. Many authors and publishers also upload their work to specific websites, granting readers access to their content without any charge. These platforms not only provide access to existing literature but also serve as an excellent platform for undiscovered authors to share their work with the world. However, it is essential to be cautious while downloading 97 Mustang Service Manual. Some websites may offer pirated or illegally obtained copies of copyrighted material. Engaging in such activities not only violates copyright laws but also undermines the efforts of authors, publishers, and researchers. To ensure ethical downloading, it is advisable to utilize reputable websites that prioritize the legal distribution of content. When downloading 97 Mustang Service Manual, users should also consider the potential security risks associated with online platforms. Malicious actors may exploit vulnerabilities in unprotected websites to distribute malware or steal personal information. To protect themselves, individuals should ensure their devices have reliable antivirus software installed and validate the legitimacy of the websites they are downloading from. In conclusion, the ability to download 97 Mustang Service Manual has transformed the way we access information. With the convenience, cost-effectiveness, and accessibility it offers, free PDF downloads have become a popular choice for students, researchers, and book lovers worldwide. However, it is crucial to engage in ethical downloading practices and prioritize personal security when utilizing online platforms. By doing so, individuals can make the most of the vast array of free PDF resources available and embark on a journey of continuous learning and intellectual growth.

FAQs About 97 Mustang Service Manual Books

What is a 97 Mustang Service Manual PDF? A PDF (Portable Document Format) is a file format developed by Adobe that preserves the layout and formatting of a document, regardless of the software, hardware, or operating system used to view or print it. **How do I create a 97 Mustang Service Manual PDF?** There are several ways to create a PDF: Use software like Adobe Acrobat, Microsoft Word, or Google Docs, which often have built-in PDF creation tools. Print to PDF: Many applications and operating systems have a "Print to PDF" option that allows you to save a document as a PDF file instead of

printing it on paper. Online converters: There are various online tools that can convert different file types to PDF. **How do I edit a 97 Mustang Service Manual PDF?** Editing a PDF can be done with software like Adobe Acrobat, which allows direct editing of text, images, and other elements within the PDF. Some free tools, like PDFescape or Smallpdf, also offer basic editing capabilities. **How do I convert a 97 Mustang Service Manual PDF to another file format?** There are multiple ways to convert a PDF to another format: Use online converters like Smallpdf, Zamzar, or Adobe Acrobats export feature to convert PDFs to formats like Word, Excel, JPEG, etc. Software like Adobe Acrobat, Microsoft Word, or other PDF editors may have options to export or save PDFs in different formats. **How do I password-protect a 97 Mustang Service Manual PDF?** Most PDF editing software allows you to add password protection. In Adobe Acrobat, for instance, you can go to "File" -> "Properties" -> "Security" to set a password to restrict access or editing capabilities. Are there any free alternatives to Adobe Acrobat for working with PDFs? Yes, there are many free alternatives for working with PDFs, such as: LibreOffice: Offers PDF editing features. PDFsam: Allows splitting, merging, and editing PDFs. Foxit Reader: Provides basic PDF viewing and editing capabilities. How do I compress a PDF file? You can use online tools like Smallpdf, ILovePDF, or desktop software like Adobe Acrobat to compress PDF files without significant quality loss. Compression reduces the file size, making it easier to share and download. Can I fill out forms in a PDF file? Yes, most PDF viewers/editors like Adobe Acrobat, Preview (on Mac), or various online tools allow you to fill out forms in PDF files by selecting text fields and entering information. Are there any restrictions when working with PDFs? Some PDFs might have restrictions set by their creator, such as password protection, editing restrictions, or print restrictions. Breaking these restrictions might require specific software or tools, which may or may not be legal depending on the circumstances and local laws.

Find 97 Mustang Service Manual :

state estimates of outputs employment and payrolls 1947 1958 1963

statistical methods for the reliability of repairable systems

statistical inference for management and economics

statics formfinding and dynamics of airsupported membrane structures

statistical reasoning 3rd ed. a&b pub

statistical analysis of experimental dat

state-of-mind

statik im erdbau 3e

statistical methods for health sciences

statistical methods in biology 2nd edition

stealing the language the emergence of w
staying healthy with diabetes a guide for the chinese american community
steady storm of correspondence selected letters of gwen harwood 1943-1995
 staying sane when your family comes to visit
stationen deutscher aubenpolitik

97 Mustang Service Manual :

it came from ohio my life as a writer goosebumps - Feb 28 2022

web apr 28 2015 it came from ohio my life as a writer goosebumps kindle edition by stine r l download it once and read it on your kindle device pc phones or tablets use features like bookmarks note taking and highlighting while reading it came from ohio my life as a writer goosebumps

it came from ohio goosebumps wiki fandom - Oct 19 2023

web it came from ohio is the autobiography of r l stine about how he came to be a writer it talks about his childhood his life in college his early jobs his wife and how he came up with the ideas for fear street and goosebumps

it came from ohio my life as a writer book 2015 worldcat org - Feb 11 2023

web it came from ohio my life as a writer r l stine joe arthur susan lurie a portrait of the author of the goosebumps series shares insight into his childhood education and literary inspirations with answers to frequently asked questions about his life books and

it came from ohio my life as a writer goosebumps open - Jan 10 2023

web apr 28 2015 it came from ohio my life as a writer goosebumps by r l stine 3 50 2 ratings 18 want to read 1 currently reading 4 have read

it came from ohio my life as a writer goosebumps - Aug 17 2023

web a portrait of the author of the goosebumps series telling readers what r l stine was lik it came from ohio my life as a writer goosebumps by r l stine goodreads

it came from ohio my life as a writer r l stine - Aug 05 2022

web apr 28 2015 autobiography published 04 28 2015 0 pages 177 it came from ohio my life as a writer the autobiography of rl stine has he had a horrifying life was rl stine a scary kid did he have a weird family did his friends at school think he was strange why does he like to terrify his readers

it came from ohio my life as a writer goosebumps - May 02 2022

web abebooks com it came from ohio my life as a writer goosebumps 9780545828901 by stine r l and a great selection of

similar new used and collectible books available now at great prices

[it came from ohio my life as a writer goosebumps](#) - Sep 06 2022

web apr 1 1998 buy it came from ohio my life as a writer goosebumps reprint by stine r l arthur joe isbn 9780590939447 from amazon s book store everyday low prices and free delivery on eligible orders it came from ohio my life as a writer goosebumps amazon co uk stine r l arthur joe 9780590939447 books

it came from ohio my life as a writer goosebumps - Apr 01 2022

web apr 28 2015 my life as a writer goosebumps it came from ohio my life as a writer goosebumps my life as a writer goosebumps in format pdf it came from ohio my life as a writer goosebumps download free of book in format it came from ohio my life as a writer goosebumps pdf it came from ohio

[it came from ohio my life as a writer goosebumps](#) - Apr 13 2023

web apr 28 2015 joe arthur it came from ohio my life as a writer goosebumps kindle edition by r l stine author format kindle edition 4 7 234 ratings part of goosebumps 64 books see all formats and editions kindle edition 2 99 read with our free app library binding 162 99 1 new from 162 99

it came from ohio my life as a writer by r l stine goodreads - Oct 07 2022

web 4 07 rating details 596 ratings 102 reviews as page turning as the mega bestsellers he creates each month r l stine s life story tells kids everything they ever wanted to know about his life and where he gets all his scary ideas line drawings and b w photos more

it came from ohio my life as a writer barnes noble - Mar 12 2023

web apr 28 2015 the autobiography of rl stine creator of the goosebumps series now a motion picture in theaters october 16 2015 has he had a horrifying life was rl stine a scary kid did he have a weird family did his friends at school think he was strange why does he like to terrify his readers where does he get the

it came from ohio my life as a writer goosebumps - Jul 04 2022

web amazon in buy it came from ohio my life as a writer goosebumps book online at best prices in india on amazon in read it came from ohio my life as a writer goosebumps book reviews author details and more at amazon in free delivery on qualified orders

it came from ohio my life as a writer goosebumps - Jun 15 2023

web so reader beware you re in for a scare a humorous fast paced portrait of the author of the goosebumps series tells young readers what r l stine was like as a kid how he became a writer and where he gets his ideas from read more reading age 8 12 years

it came from ohio my life as a writer goosebumps - Sep 18 2023

web apr 28 2015 my life as a writer goosebumps stine r l 9780545828901 amazon com books free delivery thursday august 17 on orders shipped by amazon over 25 order within 3 hrs 55 mins access codes and supplements are not guaranteed with used items

it came from ohio my life as a writer goosebumps - Nov 08 2022

web follow the authors r l stine joe arthur it came from ohio my life as a writer goosebumps kindle edition by r l stine author format kindle edition 4 7 232 ratings part of goosebumps 64 books see all formats and editions

it came from ohio my life as a writer google books - May 14 2023

web with a fresh new look goosebumps is set to scare a whole new generation of kids so reader beware you re in for a scare a humorous fast paced portrait of the author of the goosebumps series tells young readers what r l stine was like as a kid how he became a writer and where he gets his ideas from sign in

it came from ohio by r l stine open library - Jun 03 2022

web it came from ohio my life as a writer goosebumps by r l stine 3 50 2 ratings 19 want to read 1 currently reading 4 have read

it came from ohio my life as a writer apple books - Dec 09 2022

web apr 1 1998 revised and updated the autobiography of the master of fright rl stine the autobiography of rl stine creator of the goosebumps series now a motion picture in theaters october 16 2015 has he had a horrifying life was rl stine a scary kid did he have a weird family did his friends at school th

it came from ohio my life as a writer goosebumps - Jul 16 2023

web a humorous fast paced portrait of the author of the goosebumps series tells young readers what r l stine was like as a kid how he became a writer and where he gets his ideas from read more reading age 8 12 years print length 176

microsoft office 2013 illustrated introductory first course spiral - May 20 2022

web jan 1 1970 amazon com microsoft office 2013 illustrated introductory first course spiral bound version illustrated introductory first coursem spiral bound version ebook beskeen david w kindle store

microsoft office 2013 illustrated introductory first course - Jan 28 2023

web microsoft office 2013 illustrated introductory first course 1st edition is written by david w beskeen and published by cengage learning the digital and etextbook isbn for microsoft office 2013 illustrated introductory first course are 9781285785998 1285785991 and the print isbn are 9781285712000 1285712005

microsoft office 2013 illustrated introductory first course - Oct 25 2022

web about this edition praised by instructors for its concise focused approach and user friendly format the illustrated series engages both computer rookies and hot shots in mastering microsoft office 2013 applications quickly and efficiently

microsoft office 2013 illustrated introductory first course spiral - Oct 05 2023

web apr 5 2013 david w beskeen cengage learning apr 5 2013 computers 720 pages praised by instructors

microsoft office 2013 illustrated introductory first course - Aug 03 2023

web microsoft office 2013 illustrated introductory first course international edition friedrichsen lisa cram carol duffy jennifer beskeen david reding elizabeth amazon sg books

enhanced microsoft office 2013 illustrated introductory first - Jul 02 2023

web cengage learning feb 27 2015 computers 744 pages engage both computer rookies and hot shots in mastering microsoft office 2013 applications quickly and efficiently with the acclaimed

microsoft r office 2013 illustrated introductory first course - Aug 23 2022

web abebooks com microsoft r office 2013 illustrated introductory first course international edition 9781285092775 by friedrichsen lisa and a great selection of similar new used and collectible books available now at great prices

microsoft office 2013 introductory misty e vermaat google - Dec 27 2022

web may 28 2013 microsoft office 2013 introductory author misty e vermaat edition illustrated publisher cengage learning 2013 isbn 1285166027 9781285166025 length 1432 pages subjects

microsoft office 2013 illustrated introductory first course - Sep 04 2023

web apr 8 2013 there is a newer edition of this item only 1 left in stock order soon praised by instructors for its concise focused approach and user friendly format the illustrated series engages both computer rookies and hot shots in mastering microsoft office 2013 applications quickly and efficiently

microsoft office 2013 illustrated introductory first course - Mar 18 2022

web printing and materials distribution print components download and or print option available

microsoft word 2013 illustrated introductory amazon com - Jul 22 2022

web jul 24 2013 praised by instructors for its concise focused approach and user friendly format the illustrated series engages both computer rookies and hot shots in mastering microsoft word 2013 quickly and efficiently

microsoft office 2013 illustrated introductory first course buy - Apr 18 2022

web apr 2 2013 coupon rent microsoft office 2013 illustrated introductory first course 1st edition 9781285088457 and save up to 80 on textbook rentals and 90 on used textbooks get free 7 day instant etextbook access

microsoft office 2013 illustrated introductory first course goodreads - Feb 26 2023

web may 15 2013 praised by instructors for its concise focused approach and user friendly format the illustrated series engages both computer rookies and hot shots in mastering microsoft office 2013 applications quickly and efficiently

office 2013 introduction university of pittsburgh - Feb 14 2022

web office 2013 is the first version of the office suite to integrate with the office 365 environment this includes the onedrive cloud storage space and pitt email outlook all university students faculty and staff have access to the office 365 environment all students and teaching faculty are licensed to use the entire range of web based

enhanced microsoft office 2013 illustrated introductory first - Mar 30 2023

web feb 27 2015 enhanced microsoft office 2013 illustrated introductory first course david w beskeen carol m cram jennifer duffy lisa friedrichsen elizabeth eisner reding cengage learning feb 27 2015

microsoftoffice 2013 illustrated introductory first abebooks - Nov 25 2022

web microsoftoffice 2013 illustrated introductory first course spiral bound version softcover beskeen david w 3 33 avg rating 6 ratings by goodreads softcover isbn 10 128508845x isbn 13 9781285088457 publisher cengage learning 2013 view all copies of this isbn edition synopsis about this title about this edition

microsoft office 2013 illustrated introductory first course book - Jun 01 2023

web 2013 illustrated introductory first course nov 13 2021 engage both computer rookies and hot shots in mastering microsoft office 2013 applications quickly and efficiently with the acclaimed illustrated series newest book enhanced microsoft office 2013

microsoft r office 2013 illustrated introductory first course - Sep 23 2022

web microsoft r office 2013 illustrated introductory first course international edition by lisa friedrichsen carol cram jennifer duffy write the first customer review browse related subjects computers desktop applications suites

enhanced microsoftoffice 2013 illustrated introductory first - Apr 30 2023

web mar 6 2015 enhanced microsoftoffice 2013 illustrated introductory first course spiral bound version beskeen david w cram carol m duffy jennifer friedrichsen lisa reding elizabeth eisner 9781305409026 amazon com books books computers technology software buy new 25 38 list price 179 95 details save 154 57 86

microsoft office 2013 illustrated introductory first course - Jun 20 2022

web apr 2 2013 find the best prices on microsoft office 2013 illustrated introductory first course by beskeen david w at biblio unknown 2013 course technology 9781285088457

yamaha fjr 1300 1300 a ab modelljahr 2001 - Sep 22 2021

web yamaha fjr 1300 1300 a ab modelljahr 2001 reparaturanleitungen by franz josef schermer yamaha fjr1300 2001 2012 review speed specs amp prices june 1st 2020

yamaha fjr 1300 1300 a ab modelljahr 2001 - Jan 27 2022

web june 1st 2020 yamaha fjr 1300 2005 2006 the 2005 yamaha fjr 1300 is a powerful touring machine that promises to put a smile on the rider s face with every twist of the throttle

yamaha fjr 1300 1300 a ab modelljahr 2001 - Feb 25 2022

web yamaha fjr 1300 1300 a ab modelljahr 2001 reparaturanleitungen by franz josef schermer june 1st 2020 2004 yamaha fjr1300 yamaha fjr 1300 2004 propre

yamaha fjr 1300 ae kullanıcıları bilgi paylaşım başlığı - Jan 07 2023

web temiz ve sessiz çalışan tahrik shaft sistemi standart olarak yan saklama yerleri ısıtmalı elcikler ve 12 v soket teknik Özellikler motor tipi sıvı soğutmalı 4 zamanlı

yamaha fjr1300 2016 serisi touring Ötesi motorcular com - Aug 02 2022

web dec 1 2015 yamaha fjr1300 2016 serisi touring Ötesi 01 12 2015 fjr1300 modelleri artık yüksek hızlarda ve yüksek viteslerde giderken azaltılmış rpm ve arttırılmış

yamaha fjr 1300 1300 a ab modelljahr 2001 - Apr 10 2023

web jun 19 2023 yamaha fjr 1300 1300 a ab modelljahr 2001 reparaturanleitungen by franz josef schermer your yamah yamaha fjr 1300 as cliquez roulez 2012 10 02 les

yamaha fjr 1300 1300 a ab modelljahr 2001 - Apr 29 2022

web manuals yamaha fjr 1300 abs test 2015 2019 yamaha fjr1300 top speed spare parts and accessories for yamaha fjr 1300 a louis yamaha fjr 1300 technical specifications

yamaha fjr 1300 1300 a ab modelljahr 2001 reparat - Oct 04 2022

web jun 7 2023 enjoy now is yamaha fjr 1300 1300 a ab modelljahr 2001 reparat below e e yamaha fjr 1300 1300 a ab modelljahr 2001 reparat pdf vla 2001 reparat pdf is

yamaha fjr 1300 1300 a ab modelljahr 2001 - Jul 01 2022

web jun 4 2023 yamaha fjr 1300 1300 a ab modelljahr 2001 reparaturanleitungen by franz josef schermer fjr 1300 a rp08 rp11 so we are a one stop shop whe seit 15 jahren ist

download yamaha fjr 1300 1300 a ab modelljahr 2001 yumpu - May 11 2023

web the one problem with plr ebooks yamaha fjr 1300 1300 a ab modelljahr 2001 reparaturanleitungen is if youre promoting a restricted number of each one your

repair manual yamaha fjr 1300 1300 a from model year 2001 - Mar 09 2023

web nov 3 2022 die reihe reparaturanleitung ist der professionelle begleiter für jeden technisch versierten schrauber schritt für schritt anleitungen machen wartung und

yamaha fjr 1300 1300 a ab modelljahr 2001 - Feb 08 2023

web jun 29 2023 yamaha fjr1300 top speed yamaha 2006 fjr1300as service manual pdf download yamaha fjr 1300 1300 a ab modelljahr 2001 yamaha fjr 1300 abs lidköping

yamaha fjr 1300 1300 a ab modelljahr 2001 - Mar 29 2022

web jun 26 2023 yamaha fjr 1300 1300 a ab modelljahr 2001 reparaturanleitungen by franz josef schermer performance sport touring motorcycles powered by seit 15 jahren

yamaha fjr 1300 service and repair manuals tmb bookshop - Aug 14 2023

web yamaha fjr 1300 2001 2005 fjr 1300 a 2003 2013 fjr 1300 as 2006 2012 wartung und reperatur by matthew coombs

yamaha fjr 1300 1300 a ab modelljahr 2001 - May 31 2022

web jun 16 2023 yamaha fjr 1300 1300 a ab modelljahr 2001 handbuch für yamaha fjr 1300 1300 a ab modelljahr 2001

handbuch für pflege wartung und reperatur it franz josef

yamaha fjr 1300 1300 a ab modelljahr 2001 - Nov 24 2021

web mcn new amp used yamaha fjr1300 for sale in alberta autotrader ca yamaha fjr 1300 1300 a ab modelljahr 2001 yamaha 2006 fjr1300as service manual pdf download

yamaha fjr 1300 1300 a ab modelljahr 2001 - Jun 12 2023

web yamaha fjr 1300 1300 a ab modelljahr 2001 reparaturanleitungen by franz josef schermer 2020 yamaha fjr1300es motorcycles florence colorado 204325 may 23rd

yamaha fjr1300ae motosiklet sitesi - Dec 06 2022

web 1 298cc sıralı 4 silindirli motor fjr1300ae çekiş kontrol sistemi tcs ve hız sabitleyici gibi dahil edilen birçok gelişmiş elektronik kontrol sisteminden yararlanmaktadır elektronik

yamaha fjr 1300 1300 a ab modelljahr 2001 - Oct 24 2021

web colorado 204325 yamaha fjr 1300 1300 a ab modelljahr 2001 yamaha fjr 1300 models autoevolution yamaha fjr 1300 1300 a ab modelljahr 2001 spare parts and

yamaha fjr 1300 1300 a ab modelljahr 2001 handbuch fü - Jul 13 2023

web yamaha fjr 1300 1300 a ab modelljahr 2001 handbuch für pflege wartung und reperatur

2015 yamaha fjr 1300 ae tanıtımı motorcular com - Nov 05 2022

web yamaha fjr 1300 ae 2015 karşınızda yamaha fjr1300ae yamaha fjr1300ae ile sofistike uzun mesafe gezi aralığını genişletti standart olarak elektronik olarak

yamaha fjr 1300 1300 a ab modelljahr 2001 - Sep 03 2022

web jun 17 2023 yamaha fjr 1300 1300 a ab modelljahr 2001 reparaturanleitungen by franz josef schermer the yamaha fjr 1300 a is a 4 stroke sport touring bike with a

yamaha fjr 1300 1300 a ab modelljahr 2001 - Dec 26 2021

web may 18th 2020 yamaha fjr 1300 1300 a ab modelljahr 2001 handbuch für yamaha fjr 1300 1300 a ab staging6

sweetescape com 1 10 modelljahr 2001 handbuch für pflege